

# FINAL JEE(Advanced) EXAMINATION - 2020

(Held On Sunday 27<sup>th</sup> SEPTEMBER, 2020)

**PAPER-2**

**TEST PAPER WITH ANSWER**

## PART-1 : PHYSICS

### SECTION-1 : (Maximum Marks : 18)

- This section contains **SIX (06)** questions.
- The answer to each question is a **SINGLE DIGIT INTEGER ranging from 0 to 9, BOTH INCLUSIVE**.
- For each question, enter the correct integer corresponding to the answer using the mouse and the on-screen virtual numeric keypad in the place designated to enter the answer.
- Answer to each question will be evaluated according to the following marking scheme :
 

Full Marks	: +3	If ONLY the correct integer is entered;
Zero Marks	: 0	If the question is unanswered;
Negative Marks	: -1	In all other cases.

1. A large square container with thin transparent vertical walls and filled with water (refractive index  $\frac{4}{3}$ ) is kept on a horizontal table. A student holds a thin straight wire vertically inside the water 12 cm from one of its corners, as shown schematically in the figure. Looking at the wire from this corner, another student sees two images of the wire, located symmetrically on each side of the line of sight as shown. The separation (in cm) between these images is \_\_\_\_\_.

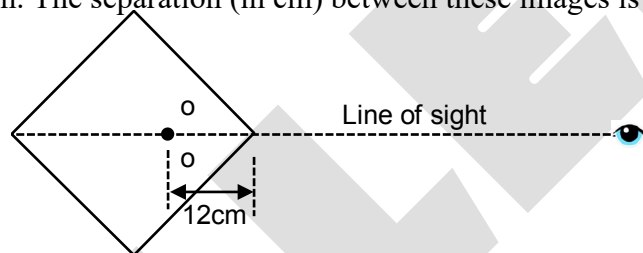

**Ans. 2**

2. A train with cross-sectional area  $S_t$  is moving with speed  $v_t$  inside a long tunnel of cross-sectional area  $S_0$  ( $S_0 = 4S_t$ ). Assume that almost all the air (density  $\rho$ ) in front of the train flows back between its sides and the walls of the tunnel. Also, the air flow with respect to the train is steady and laminar. Take the ambient pressure and that inside the train to be  $p_0$ . If the pressure in the region between the sides of the train and the tunnel walls is  $p$ , then  $p_0 - p = \frac{7}{2N} \rho v_t^2$ . The value of  $N$  is \_\_\_\_\_.

**Ans. 9**

3. Two large circular discs separated by a distance of 0.01 m are connected to a battery via a switch as shown in the figure. Charged oil drops of density  $900 \text{ kg m}^{-3}$  are released through a tiny hole at the center of the top disc. Once some oil drops achieve terminal velocity, the switch is closed to apply a voltage of 200 V across the discs. As a result, an oil drop of radius  $8 \times 10^{-7} \text{ m}$  stops moving vertically and floats between the discs. The number of electrons present in this oil drop is \_\_\_\_\_. (neglect the buoyancy force, take acceleration due to gravity  $= 10 \text{ ms}^{-2}$  and charge on an electron ( $e$ )  $= 1.6 \times 10^{-19} \text{ C}$ )

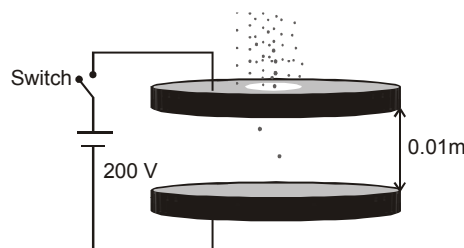

**Ans. 6**

4. A hot air balloon is carrying some passengers, and a few sandbags of mass 1 kg each so that its total mass is 480 kg. Its effective volume giving the balloon its buoyancy is  $V$ . The balloon is floating at an equilibrium height of 100 m. When  $N$  number of sandbags are thrown out, the balloon rises to a new equilibrium height close to 150 m with its volume  $V$  remaining unchanged. If the variation of the density of air with height  $h$  from the ground is  $\rho(h) = \rho_0 e^{-\frac{h}{h_0}}$ , where  $\rho_0 = 1.25 \text{ kg m}^{-3}$  and  $h_0 = 6000 \text{ m}$ , the value of  $N$  is \_\_\_\_\_.

Ans. 4

5. A point charge  $q$  of mass  $m$  is suspended vertically by a string of length  $l$ . A point dipole of dipole moment  $\vec{p}$  is now brought towards  $q$  from infinity so that the charge moves away. The final equilibrium position of the system including the direction of the dipole, the angles and distances is shown in the figure below. If the work done in bringing the dipole to this position is  $N \times (mgh)$ , where  $g$  is the acceleration due to gravity, then the value of  $N$  is \_\_\_\_\_. (Note that for three coplanar forces keeping a point mass in equilibrium,  $\frac{F}{\sin \theta}$  is the same for all forces, where  $F$  is any one of the forces and  $\theta$  is the angle between the other two forces)

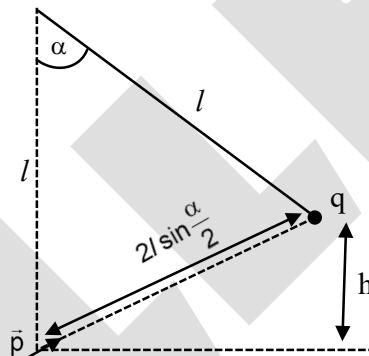

Ans. 2

6. A thermally isolated cylindrical closed vessel of height 8 m is kept vertically. It is divided into two equal parts by a diathermic (perfect thermal conductor) frictionless partition of mass 8.3 kg. Thus the partition is held initially at a distance of 4 m from the top, as shown in the schematic figure below. Each of the two parts of the vessel contains 0.1 mole of an ideal gas at temperature 300 K. The partition is now released and moves without any gas leaking from one part of the vessel to the other. When equilibrium is reached, the distance of the partition from the top (in m) will be \_\_\_\_\_ (take the acceleration due to gravity  $= 10 \text{ ms}^{-2}$  and the universal gas constant  $= 8.3 \text{ J mol}^{-1} \text{ K}^{-1}$ ).

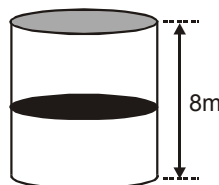

Ans. 6

**SECTION 2 (Maximum Marks : 24)**

- This section contains **SIX (06)** questions.
- Each question has **FOUR** options. **ONE OR MORE THAN ONE** of these four option(s) is (are) correct answer(s).
- For each question, choose the option(s) corresponding to (all) the correct answer(s).
- Answer to each question will be evaluated according to the following marking scheme :
 

Full Marks	: +4	If only (all) the correct option(s) is(are) chosen;
Partial Marks	: +3	If all the four options are correct but <b>ONLY</b> three options are chosen;
Partial Marks	: +2	If three or more options are correct but <b>ONLY</b> two options are chosen, both of which are correct;
Partial Marks	: +1	If two or more options are correct but <b>ONLY</b> one option is chosen and it is a correct option;
Zero Marks	: 0	If none of the options is chosen (i.e. the question is unanswered);
Negative Marks	: -2	In all other cases.

7. A beaker of radius  $r$  is filled with water (refractive index  $\frac{4}{3}$ ) up to a height  $H$  as shown in the figure on the left. The beaker is kept on a horizontal table rotating with angular speed  $\omega$ . This makes the water surface curved so that the difference in the height of water level at the center and at the circumference of the beaker is  $h$  ( $h \ll H, h \ll r$ ), as shown in the figure on the right. Take this surface to be approximately spherical with a radius of curvature  $R$ . Which of the following is/are correct? ( $g$  is the acceleration due to gravity)

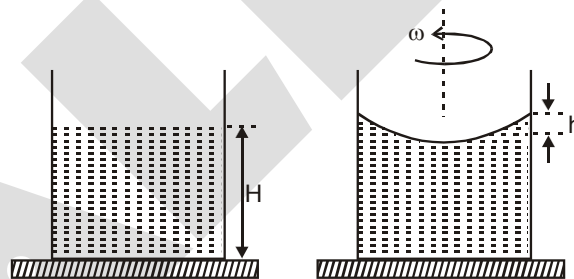

(A)  $R = \frac{h^2 + r^2}{2h}$

(B)  $R = \frac{3r^2}{2h}$

(C) Apparent depth of the bottom of the beaker is close to  $\frac{3H}{2} \left(1 + \frac{\omega^2 H}{2g}\right)^{-1}$

(D) Apparent depth of the bottom of the beaker is close to  $\frac{3H}{4} \left(1 + \frac{\omega^2 H}{4g}\right)^{-1}$

**Ans. A,D**

8. A student skates up a ramp that makes an angle  $30^\circ$  with the horizontal. He/she starts (as shown in the figure) at the bottom of the ramp with speed  $v_0$  and wants to turn around over a semicircular path  $xyz$  of radius  $R$  during which he/she reaches a maximum height  $h$  (at point  $y$ ) from the ground as shown in the figure. Assume that the energy loss is negligible and the force required for this turn at the highest point is provided by his/her weight only. Then ( $g$  is the acceleration due to gravity)

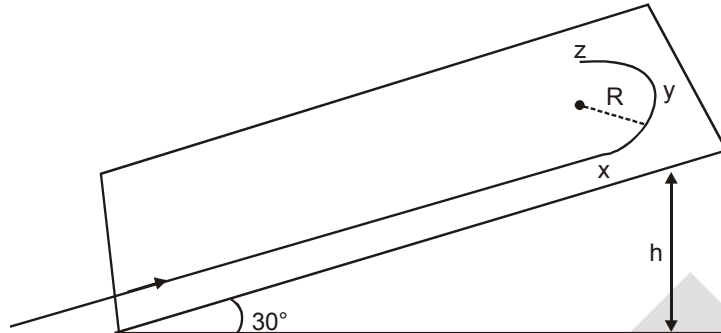

- (A)  $v_0^2 - 2gh = \frac{1}{2}gR$   
 (B)  $v_0^2 - 2gh = \frac{\sqrt{3}}{2}gR$   
 (C) the centripetal force required at points  $x$  and  $z$  is zero  
 (D) the centripetal force required is maximum at points  $x$  and  $z$

Ans. A,D

9. A rod of mass  $m$  and length  $L$ , pivoted at one of its ends, is hanging vertically. A bullet of the same mass moving at speed  $v$  strikes the rod horizontally at a distance  $x$  from its pivoted end and gets embedded in it. The combined system now rotates with angular speed  $\omega$  about the pivot. The maximum angular speed  $\omega_M$  is achieved for  $x = x_M$ . Then

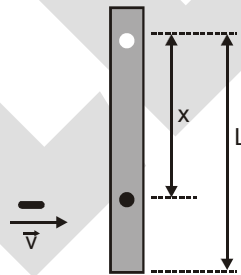

- (A)  $\omega = \frac{3vx}{L^2 + 3x^2}$       (B)  $\omega = \frac{12vx}{L^2 + 12x^2}$       (C)  $x_M = \frac{L}{\sqrt{3}}$       (D)  $\omega_M = \frac{v}{2L}\sqrt{3}$

Ans. A,C,D

10. In an X-ray tube, electrons emitted from a filament (cathode) carrying current  $I$  hit a target (anode) at a distance  $d$  from the cathode. The target is kept at a potential  $V$  higher than the cathode resulting in emission of continuous and characteristic X-rays. If the filament current  $I$  is decreased to  $\frac{I}{2}$ , the

potential difference  $V$  is increased to  $2V$ , and the separation distance  $d$  is reduced to  $\frac{d}{2}$ , then

- (A) the cut-off wavelength will reduce to half, and the wavelengths of the characteristic X-rays will remain the same  
 (B) the cut-off wavelength as well as the wavelengths of the characteristic X-rays will remain the same  
 (C) the cut-off wavelength will reduce to half, and the intensities of all the X-rays will decrease  
 (D) the cut-off wavelength will become two times larger, and the intensity of all the X-rays will decrease

Ans. A,C

11. Two identical non-conducting solid spheres of same mass and charge are suspended in air from a common point by two non-conducting, massless strings of same length. At equilibrium, the angle between the strings is  $\alpha$ . The spheres are now immersed in a dielectric liquid of density  $800 \text{ kg m}^{-3}$  and dielectric constant 21. If the angle between the strings remains the same after the immersion, then
- electric force between the spheres remains unchanged
  - electric force between the spheres reduces
  - mass density of the spheres is  $840 \text{ kg m}^{-3}$
  - the tension in the strings holding the spheres remains unchanged

Ans. A,C

12. Starting at time  $t=0$  from the origin with speed  $1 \text{ ms}^{-1}$ , a particle follows a two-dimensional trajectory in the  $x$ - $y$  plane so that its coordinates are related by the equation  $y = \frac{x^2}{2}$ . The  $x$  and  $y$  components of its acceleration are denoted by  $a_x$  and  $a_y$ , respectively. Then
- $a_x = 1 \text{ ms}^{-2}$  implies that when the particle is at the origin,  $a_y = 1 \text{ ms}^{-2}$
  - $a_x = 0$  implies  $a_y = 1 \text{ ms}^{-2}$  at all times
  - at  $t = 0$ , the particle's velocity points in the  $x$ -direction
  - $a_x = 0$  implies that at  $t = 1 \text{ s}$ , the angle between the particle's velocity and the  $x$  axis is  $45^\circ$

Ans. A,B,C,D

### SECTION 3 (Maximum Marks : 24)

- This section contains **SIX (06)** questions. The answer to each question is a **NUMERICAL VALUE**.
- For each question, enter the correct numerical value of the answer using the mouse and the on-screen virtual numeric keypad in the place designated to enter the answer. If the numerical value has more than two decimal places, **truncate/round-off** the value to **TWO** decimal places.
- Answer to each question will be evaluated according to the following marking scheme :  

Full Marks	: +4	If ONLY the correct numerical value is entered;
Zero Marks	: 0	In all other cases.

13. A spherical bubble inside water has radius  $R$ . Take the pressure inside the bubble and the water pressure to be  $p_0$ . The bubble now gets compressed radially in an adiabatic manner so that its radius becomes  $(R-a)$ . For  $a \ll R$  the magnitude of the work done in the process is given by  $(4\pi p_0 R a^2)X$ , where  $X$  is a constant and  $\gamma = C_p/C_v = 41/30$ . The value of  $X$  is \_\_\_\_\_.

Ans. 1.05

14. In the balanced condition, the values of the resistances of the four arms of a Wheatstone bridge are shown in the figure below. The resistance  $R_3$  has temperature coefficient  $0.0004 \text{ }^\circ\text{C}^{-1}$ . If the temperature of  $R_3$  is increased by  $100 \text{ }^\circ\text{C}$ , the voltage developed between  $S$  and  $T$  will be \_\_\_\_\_ volt.

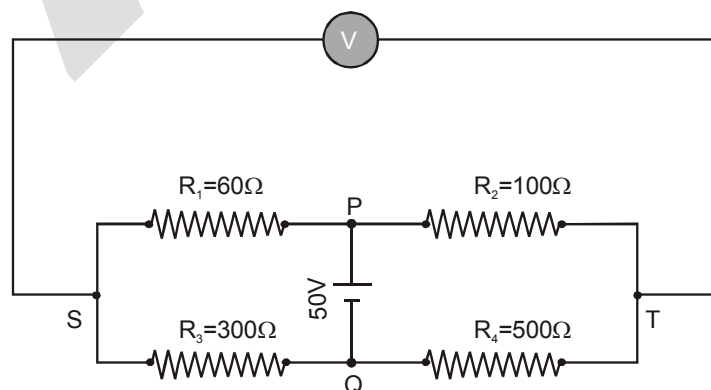

Ans. 0.26 To 0.27

15. Two capacitors with capacitance values  $C_1 = 2000 \pm 10$  pF and  $C_2 = 3000 \pm 15$  pF are connected in series. The voltage applied across this combination is  $V = 5.00 \pm 0.02$  V. The percentage error in the calculation of the energy stored in this combination of capacitors is \_\_\_\_\_.

Ans. 1.30

16. A cubical solid aluminium (bulk modulus  $= -V \frac{dP}{dV} = 70$  GPa) block has an edge length of 1 m on the surface of the earth. It is kept on the floor of a 5 km deep ocean. Taking the average density of water and the acceleration due to gravity to be  $10^3$  kg m<sup>-3</sup> and  $10$  ms<sup>-2</sup>, respectively, the change in the edge length of the block in mm is \_\_\_\_\_.

Ans. 0.23 To 0.24

17. The inductors of two  $LR$  circuits are placed next to each other, as shown in the figure. The values of the self-inductance of the inductors, resistances, mutual-inductance and applied voltages are specified in the given circuit. After both the switches are closed simultaneously, the total work done by the batteries against the induced  $EMF$  in the inductors by the time the currents reach their steady state values is \_\_\_\_\_ mJ.

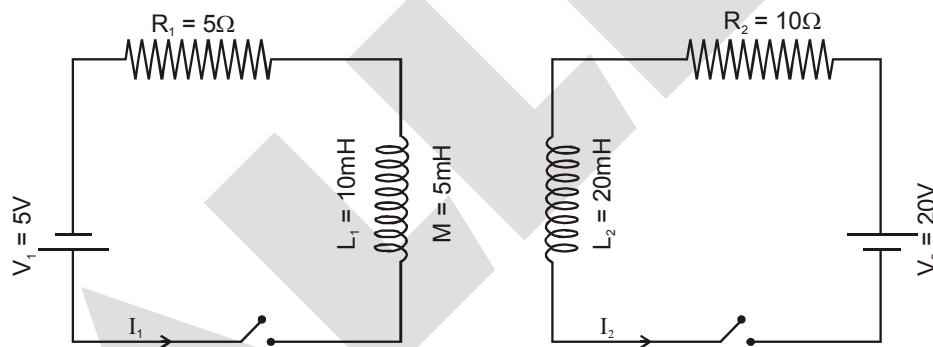

Ans. 55.00

18. A container with 1 kg of water in it is kept in sunlight, which causes the water to get warmer than the surroundings. The average energy per unit time per unit area received due to the sunlight is  $700Wm^{-2}$  and it is absorbed by the water over an effective area of  $0.05$  m<sup>2</sup>. Assuming that the heat loss from the water to the surroundings is governed by Newton's law of cooling, the difference (in °C) in the temperature of water and the surroundings after a long time will be \_\_\_\_\_. (Ignore effect of the container, and take constant for Newton's law of cooling =  $0.001$  s<sup>-1</sup>, Heat capacity of water =  $4200$  J kg<sup>-1</sup> K<sup>-1</sup>)

Ans. 8.33

मेरी कोचिंग  
अब मेरे घर पर

India's Best  
Faculty Team is  
my preference

**ALLEN**<sup>®</sup>

presents



**ALLEN Digital**

*Best academics meet Best technology*

Introducing

• **Live Online Classes** along with

**Interactive Happy Learning (IHL)**

**Video Lectures**

**JEE (Main + Adv.) | JEE (Main) | NEET-UG**

**PNCF | e-Boards | e-Doubt Solutions**



**: [www.allen.ac.in](http://www.allen.ac.in)**



**: 8306814555**